

# RHINO CARBON FIBER™ BOWED WALL INSTRUCTIONS

U.S. Patent No. 8,584,431 | Canadian Patent No. 2,738,005 | Revision Date 02/20/2019

1633 Thornwood Dr.  
Heath, OH 43056 USA  
P: +1 888 684 3889  
E: info@rhinocarbonfiber.com

01

## WHAT COMES IN THE BOWED WALL REPAIR KIT?



### KIT INCLUDES

(TOOLS MAY VARY DEPENDING ON PROJECT)

- (3) 5.5" wide carbon fiber straps (length is determined by kit)
- (2) Tubes of Saturant-Adhesive Epoxy
- (2) Static epoxy mixing nozzles
- (3) Sill plate brackets
- (6) Bolts and washers
- Gloves and Instructions

### PRODUCTS COMMONLY USED WITH BOWED WALL REPAIR



Rhino Carbon Fiber™ Dual Epoxy Gun  
300/300 ml or 300/150 ml gun



RCF™ High Strength Anchoring Epoxy Paste  
Can be used to fill in cracks



Tough Wipes by Rhino Carbon Fiber™  
Removes Epoxy!

## RECOMMENDED POWER TOOLS

(TOOLS MAY VARY DEPENDING ON PROJECT)

### 5-Inch Surface Grinding Dust Shroud Kit



Use for grinding foundation wall  
\*\*USE DIAMOND CUP WHEEL

### 10-Gallon Dust Extractor



Collects dust while attached to  
grinder and shroud tools

### Tuck Point Grinder with Dust Shroud Attachment



Use to tuckpoint the wall  
\*\*USE DIAMOND TIP BLADE

### Hammer Drill



Use for concrete removal  
\*\*USE CHISEL OR SPADE TIP ATTACHMENT

## YOU WILL ALSO NEED...

- Safety goggles
- Respirator mask
- Epoxy gun
- Coveralls
- Drop cloth/ plastic
- Scissors
- Marker
- Hard hat
- Putty knife
- Measuring tape
- Power drill (1/4" Bit)

## SAFETY WARNINGS

Please read and follow safety procedures for all tools and wear proper safety equipment during installation.

While using power tools, follow all EPA/OSHA guidelines for lead paint removal and respiratory protection. For more information visit [www.epa.gov](http://www.epa.gov) or [www.osha.gov](http://www.osha.gov).



1-888-684-3889 | [www.RhinoCarbonFiber.com](http://www.RhinoCarbonFiber.com)

© All Rights Reserved

None of the authors, contributors, administrators, or anyone else connected with Rhino Products USA Inc. or any of its affiliates (collectively, "Rhino"), in any way whatsoever, can be responsible for your use of the information, instructions or advice contained in or linked from this or any related document. All liability with respect to actions taken or not taken based on the contents of this or any related document is hereby expressly disclaimed by Rhino. The content of this document is provided "as is;" no representations are made that the content is error-free.

# RHINO CARBON FIBER™ BOWED WALL INSTRUCTIONS

U.S. Patent No. 8,584,431 | Canadian Patent No. 2,738,005 | Revision Date 02/20/2019

1633 Thornwood Dr.  
Heath, OH 43056 USA  
P: +1 888 684 3889  
E: info@rhinocarbonfiber.com

02

PLEASE READ ALL DIRECTIONS CAREFULLY & WEAR SAFETY GOGGLES DURING INSTALLATION



## 01 PREP AND GRIND

- Lay plastic or drop cloth around work surface
  - Measure and mark locations of the straps
  - Grind the vertical length of the foundation wall where carbon fiber strap will be installed. Remove paint, coatings and glossy surfaces to achieve a "Bare Foundation" (Even uncoated blocks need to be ground to expose the aggregate in the blocks)
  - Round top corner of block where strap will be located
  - Carbon Fiber strap should span from sill plate to floor
  - Remove caulk/latex/loose mortar/etc. from mortar joints
  - Use opposing mortar joints as a guide
- \*READ AND FOLLOW ALL EPA AND OSHA SAFETY PRACTICES

Tools: marker, measuring tape, plastic or dropcloth, grinder

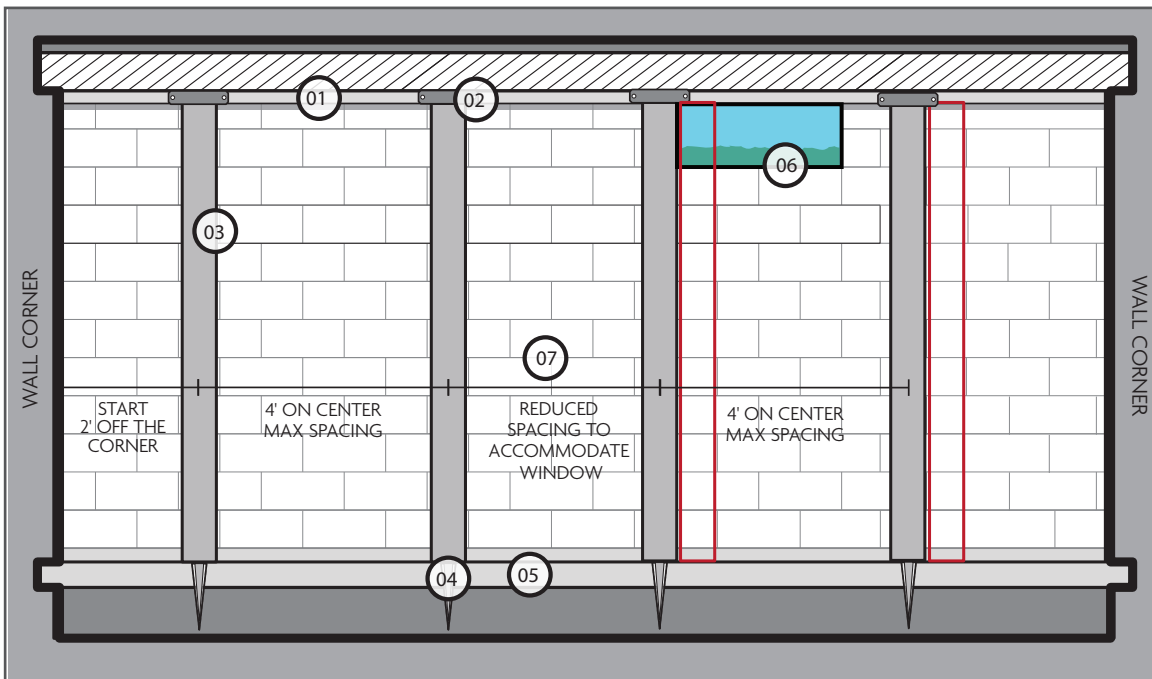

- 01: Sill Plate
- 02: Sill Plate Bracket
- 03: Carbon Fiber Strap
- 04: Carbon Fiber Pin
- 05: Concrete Floor
- 06: Obstacle
- 07: Adjust spacing as necessary to avoid obstacles

Max spacing is 2' off corners and 4' on center across the wall.

Refer to spacing chart or project specific design for the appropriate strip spacing.



## 02 REPAIR CRACKS

- Repair all cracks by using hydraulic cement or High Strength Anchoring Epoxy Paste before installing carbon fiber
- \*Wall must be completely bare and clean with cracks/deep mortar joints filled before applying carbon fiber
- \*Check our Rhino tuck point instruction video on YouTube for reference

Tools: hammer drill, hydraulic cement or High Strength Anchoring Epoxy Paste



1-888-684-3889 | [www.RhinoCarbonFiber.com](http://www.RhinoCarbonFiber.com)

© All Rights Reserved

None of the authors, contributors, administrators, or anyone else connected with Rhino Products USA Inc. or any of its affiliates (collectively, "Rhino"), in any way whatsoever, can be responsible for your use of the information, instructions or advice contained in or linked from this or any related document. All liability with respect to actions taken or not taken based on the contents of this or any related document is hereby expressly disclaimed by Rhino. The content of this document is provided "as is;" no representations are made that the content is error-free.

# RHINO CARBON FIBER™ BOWED WALL INSTRUCTIONS

U.S. Patent No. 8,584,431 | Canadian Patent No. 2,738,005 | Revision Date 02/20/2019

1633 Thornwood Dr.  
Heath, OH 43056 USA  
P: +1 888 684 3889  
E: info@rhinocarbonfiber.com

03



## 03 SILL PLATE PREP

- Mark drill holes with pencil or pen for the sill plate bracket
- Make sure the sill plate bracket is level with the top of the foundation wall and centered over the area where the strap will be installed
  - \*An uneven Bracket could cause splitting and damage to the sill plate
- Pre-drill holes using a 1/4" drill bit
- Pre-drilled holes will ensure a secure connection between the carbon fiber, sill plate

Tools: pencil/pen, power drill with 1/4" Bit



## 04 DRILL FOOTING

- Using a hammer drill, pre-drill a 3/4" hole at the center of the prepped carbon fiber location
- Drill hole as close to vertical as possible against the base of the wall.
- If the floor is sound, pinning to the floor is sufficient.
- If the floor is being removed or is deteriorated, remove floor and pin directly to the footer.

Tools: hammer drill,



## 05 ATTACH SILL PLATE

- TIP: Lay carbon fiber on piece of cardboard
- Apply epoxy to the top 8" of the carbon fiber, spread epoxy so that the strap is saturated
  - Lay bracket flush with the top of carbon fiber
  - Roll bracket and carbon fiber twice and ensure the wrap is tight

Tools: tape measure, latex gloves and epoxy gun



## 06 MOUNT

- Mount the saturated carbon fiber wrapped sill plate bracket unit
- Check for level of sill plate bracket to ensure a secure fit to sill plate
- Fasten sill plate bracket to the sill plate using the supplied (2) 3/8" x 2" lag bolts and (2) washers

Tools: drill, level, lag bolts and flat washers

# RHINO BOWED WALL INSTRUCTIONS

U.S. Patent No. 8,584,431

1633 Thornwood Dr.  
Heath, OH 43056 USA  
P: +1 888 684 3889  
E: info@rhinocarbonfiber.com

04

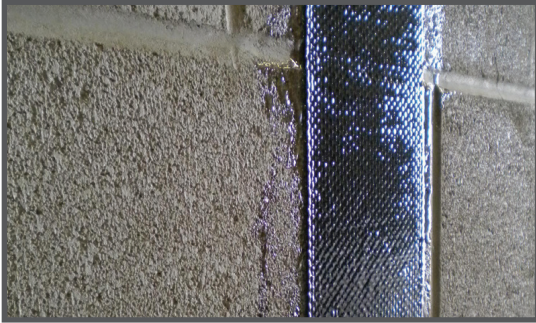

## 07 EPOXY

TIP: Roll carbon fiber and sit on sill plate ledge so that it is out of the way

- Apply an even coat of epoxy to the wall over the entire area where the strap will meet the wall
- Once a sufficient coating of epoxy is applied to foundation wall, lay the carbon fiber strap over the applied epoxy making sure that the carbon fiber strap is straight and tight
- Work the carbon fiber into the epoxy with trowel, spatula, roller, or gloved hands.
- Apply a second layer of epoxy on top of the carbon fiber and lightly spread the epoxy with a putty knife to provide an even finish

Tools: putty knife, gloves, epoxy adhesive, epoxy gun, static nozzle



01: Lift carbon fiber strap & apply epoxy to wall



02: Spread epoxy on foundation wall



03: Apply carbon fiber strap & coat with epoxy



## 08 ANCHOR

- Secure bottom of the carbon fiber strap as per the diagram below
- If there is extra carbon fiber; cut the excess at this time (leave 6" to 8" of carbon fiber beyond the bottom of the wall for the shear pin)
- Fill the hole with epoxy and saturate the remainder of the strap
- Fold bottom of strap to make a point (triangle tip) then twist to create the pin
- Insert pin into hole and top off with epoxy

FINAL STEP

- Use light strokes with putty knife to spread epoxy evenly, focusing on the edges for a clean and secure installation
- Make sure the strap is tightly adhered to the wall all the way to the floor

Tools: gloves, epoxy gun, putty knife

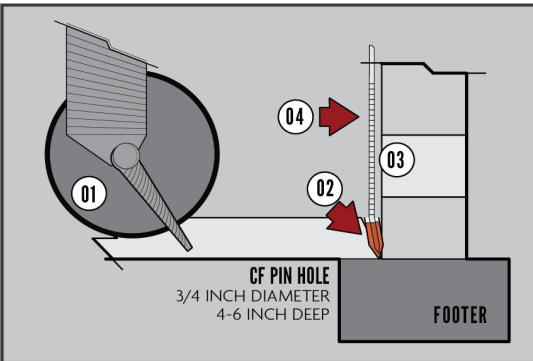

Apply epoxy to hole



Twist carbon fiber and insert into hole

- 01: Fold and twist end of carbon fiber strap to make pin  
02: Fill hole with epoxy and place carbon fiber twisted pin inside hole  
03: After pin is inserted, make sure strap is tightly adhered to wall  
04: Top off hole with epoxy

\*\* When waterproofing, or if floor is deteriorated, the strap can be pinned to the footer.



1-888-684-3889 | [www.RhinoCarbonFiber.com](http://www.RhinoCarbonFiber.com)

© All Rights Reserved

None of the authors, contributors, administrators, or anyone else connected with Rhino Products USA Inc. or any of its affiliates (collectively, "Rhino"), in any way whatsoever, can be responsible for your use of the information, instructions or advice contained in or linked from this or any related document. All liability with respect to actions taken or not taken based on the contents of this or any related document is hereby expressly disclaimed by Rhino. The content of this document is provided "as is;" no representations are made that the content is error-free.